



# INTERLOC RIGID SYSTEM

**"INTERLOC RIGID"**

The Interloc Rigid System is designed for very long reach tooling to utilize maximum strength and rigidity when machining steel, aluminum, or other exotic materials. With a triple contact on the spindle the Interloc Rigid helps reduce the amount of wear on the machine and the machine spindle. This triple contact also increases tooling life, feed rates, and depth of cut when machining. The Interloc Rigid System is also modular and allows you to interchange with various Interloc extensions, adapters, reducers, and cutters.

MFH Holders have a 4" bolt down circle & a 5.062" flange diameter that bolts down to your machine spindle head which gives you the benefit of being more rigid than the conventional CAT 40 or CAT 50 Holders. MFH Holders are part of the "Interloc Rigid System" which allows you to combine and interchange a wide range of tooling solutions using the modular Interloc connection system.

## Standard Flange Mount Holders

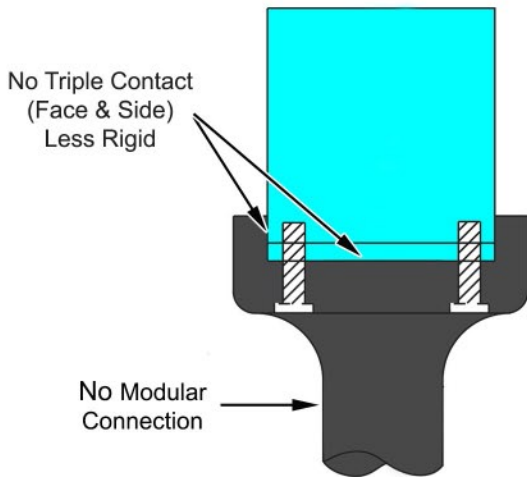

## Interloc Rigid Flange Mount Holders

### SOLID TRIPLE CONTACT

100% Triple Contact On Spindle, Taper, & Face (NO GAP!)

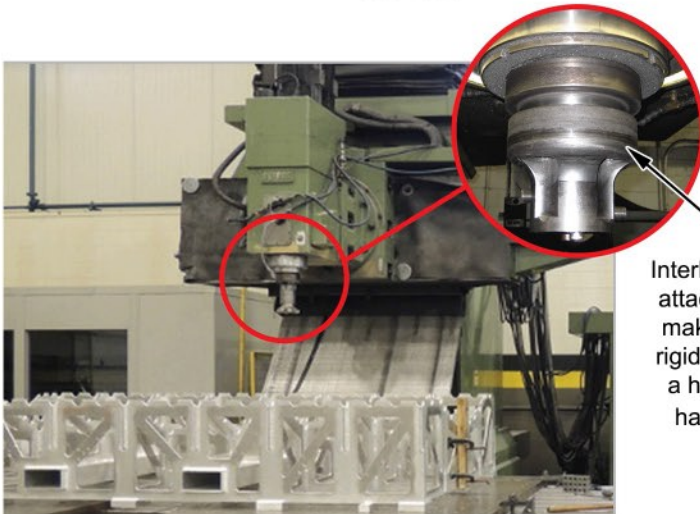
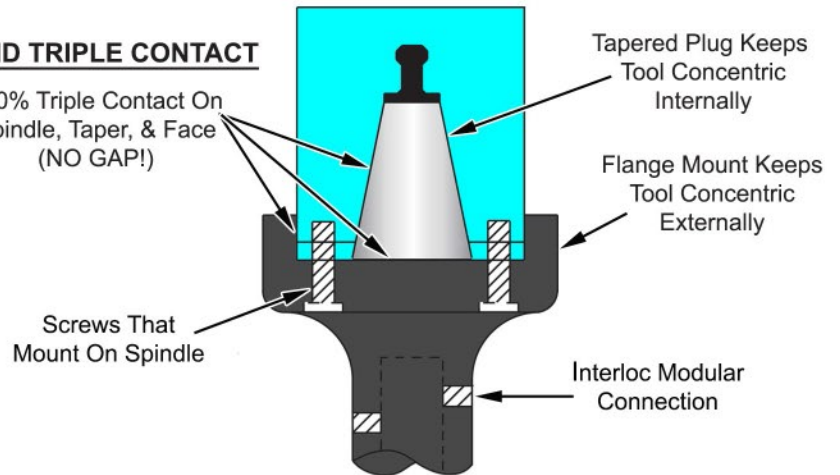

Interloc Rigid MFH holders will fit most standard bolt down machine spindle heads & have a tapered plug available in CAT-50 or CAT-50 NMTB.

Interloc MFH Holders will attach directly to spindle making it more stable & rigid allowing you to take a heavy depth of cut & having less vibration.



**LONG REACH:** Interloc Rigid Can Extend Over 30 Inches

## INTERLOC RIGID BENEFITS

- Triple Contact On Spindle, Taper, & Face
- Up To 50% Feed Rate Increase
- Increase Depth of Cut
- Extremely Rigid & Stable
- Decrease Vibration
- Increase Tooling Life & Accuracy

# COMBINING THE INTERLOC RIGID CONNECTION SYSTEM

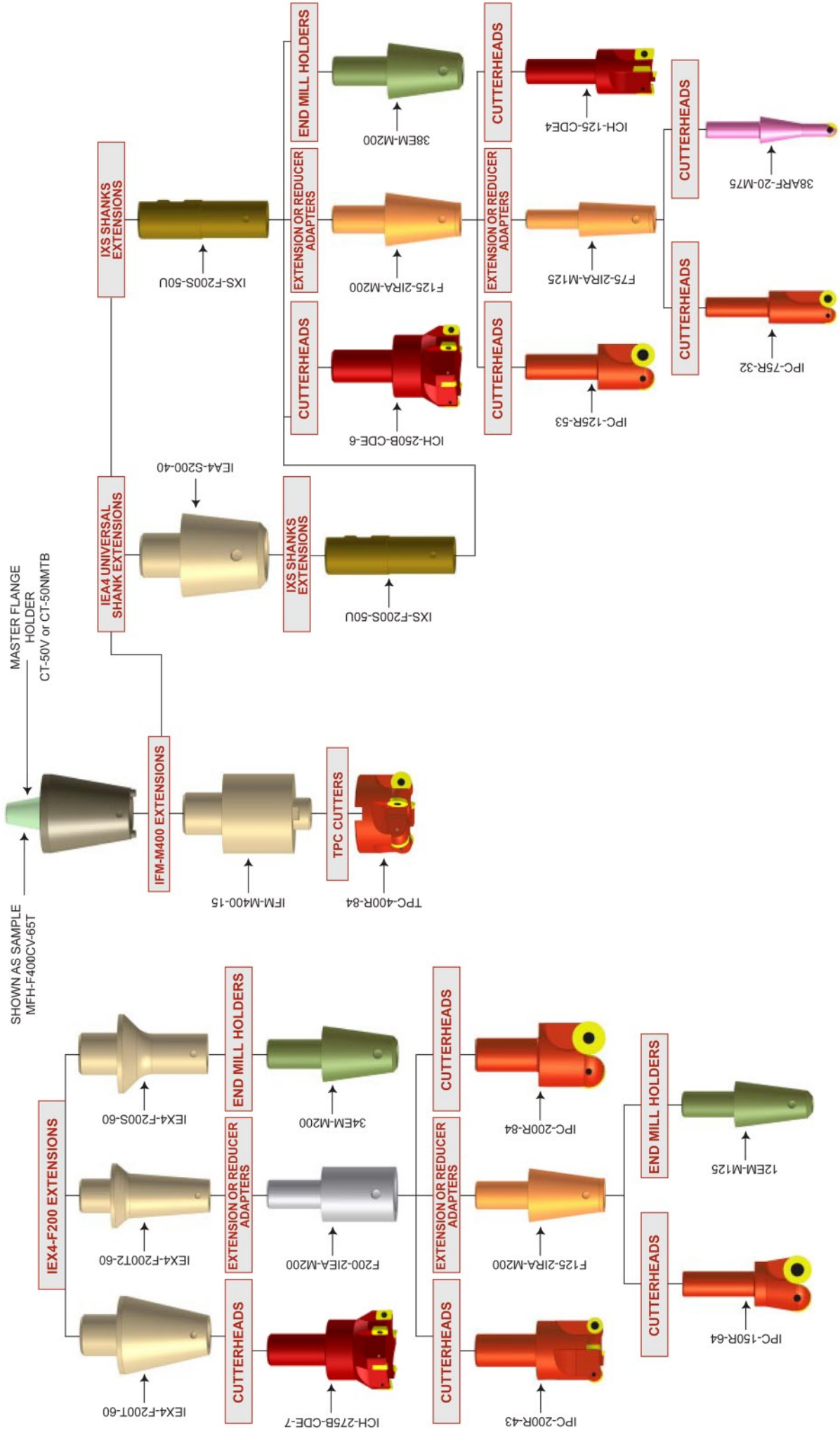

# INTERLOC MASTER FLANGE HOLDER

"INTERLOC RIGID"

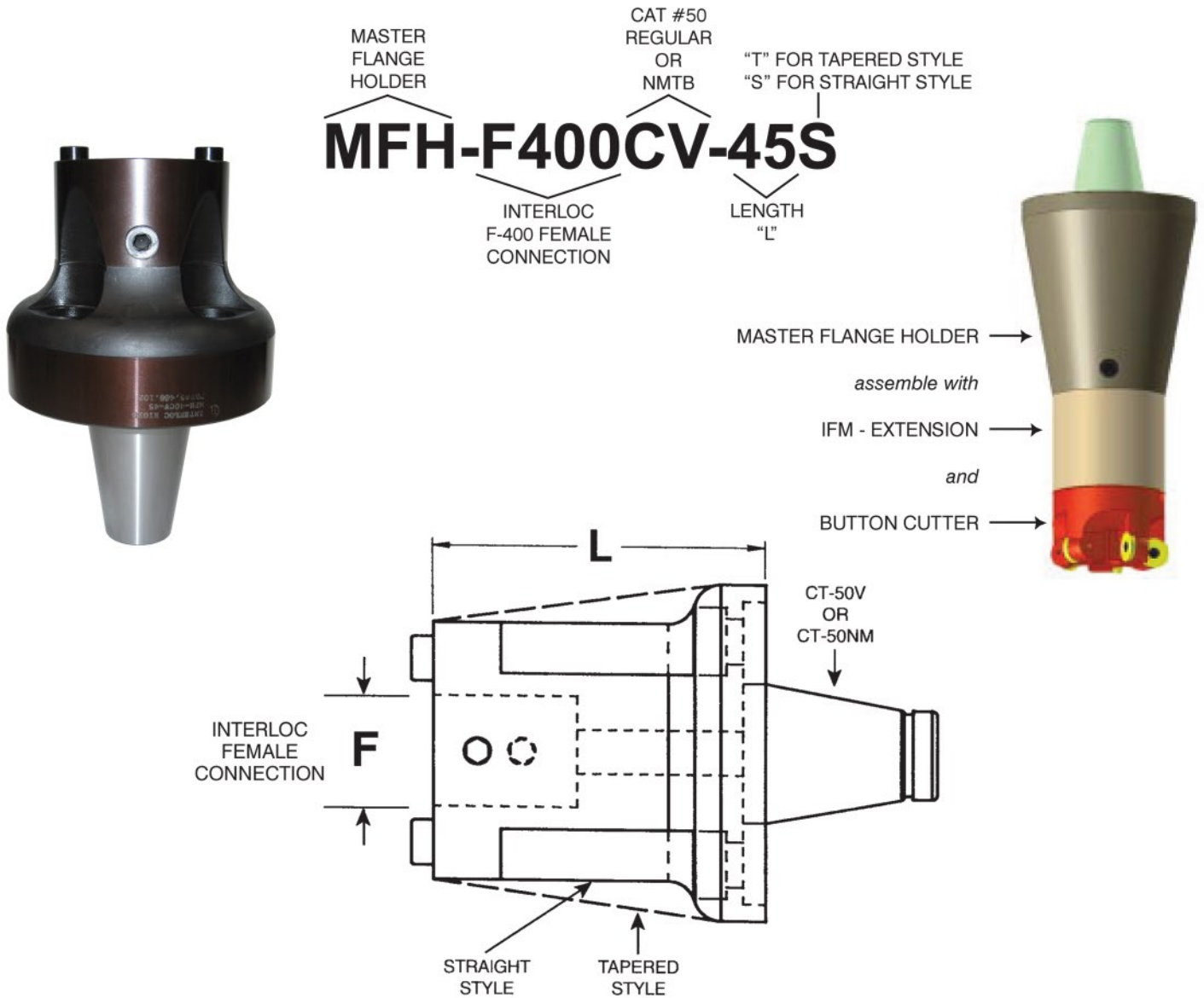

❖ Cooling through shanks available

\* Semi-special

◆ Custom sizes available

CATALOG NUMBER	INTERLOC FEMALE CONNECTION (F)	LENGTH (L)	LOCK SCREW	KEYWAY	KEYWAY SCREW
MFH-F400CV-45S	F400 INTERLOC	4.500	TS-625	TK-625	10 x 1.00
MFH-F400CV-65T		6.500			
MFH-F400CV-85T		8.500			
MFH-F400CV-105T		10.500			
MFH-F400CV-130T		13.000			

# INTERLOC TAPERED REACH EXTENSION

\* Assemble with Master Flanges \*

\* Assembles with extensions, reducers, endmill holders and cutterheads \*

**"INTERLOC RIGID"**



INTERLOC EXTENSION  
"M" - MALE CONNECTION

TAPER STYLE

## IEX4-F200T-60

INTERLOC "F" - FEMALE CONNECTION

LENGTH "L"

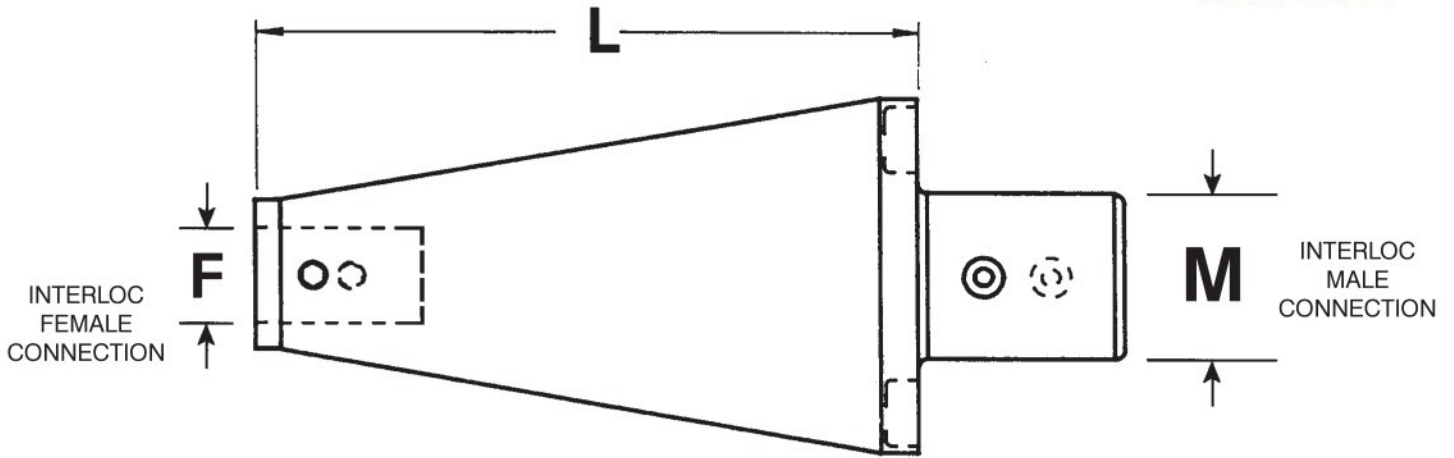
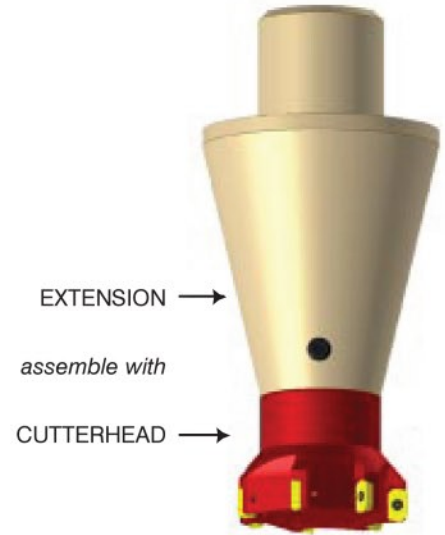

❖ Cooling through shanks available

\* Semi-special

▲ Custom lengths available

CATALOG NUMBER	INTERLOC FEMALE CONNECTION (F)	INTERLOC MALE CONNECTION (M)	LENGTH (L)	LOCK SCREW	"T" HANDLE ALLEN WRENCH
IEX4-F200T-60	F200 INTERLOC	M400 INTERLOC	6.000	TS-375	3/16
IEX4-F200T-80			8.000		
IEX4-F200T-100			10.000		
IEX4-F200T-130			13.000		
IEX4-F200T-180*			18.000		

# INTERLOC TAPERED II REACH EXTENSION

\* Assembles with Master Flange \*  
 \* Assembles with extensions, reducers, endmill holders and cutterheads \*

**"INTERLOC RIGID"**



INTERLOC EXTENSION  
 "M" - MALE CONNECTION

TAPER STYLE #2

## IEX4-F200T2-60

INTERLOC "F" - FEMALE CONNECTION

LENGTH "L"

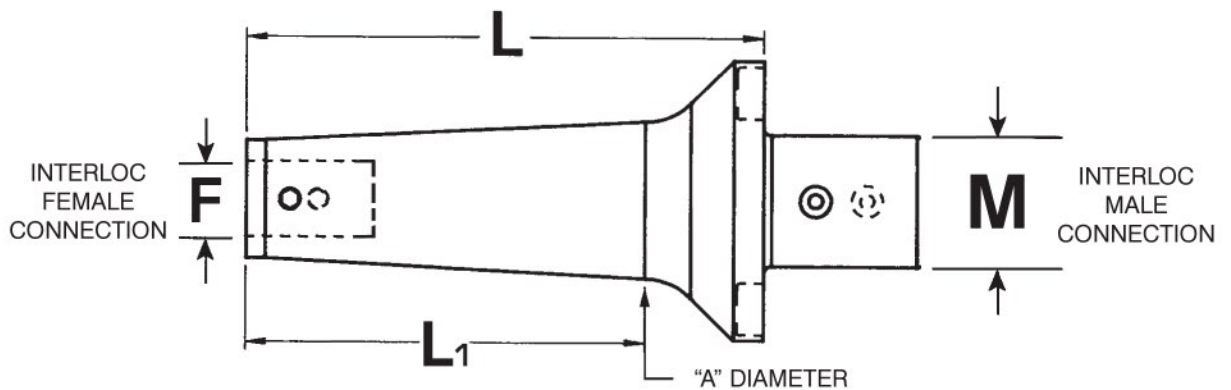
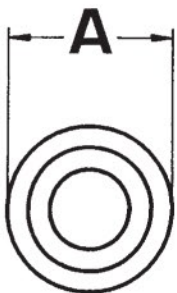
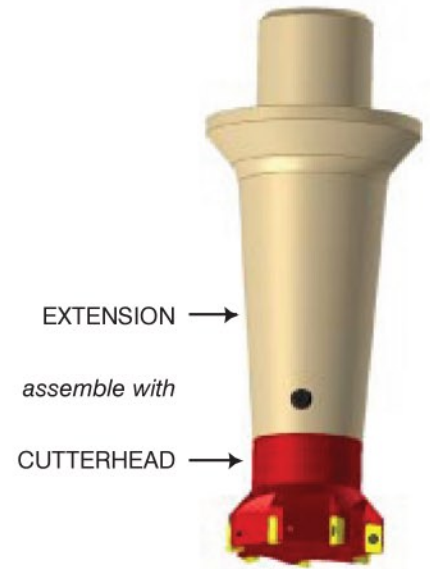

❖ Cooling through shanks available

▲ Custom lengths available

CATALOG NUMBER	INTERLOC FEMALE CONNECTION (F)	INTERLOC MALE CONNECTION (M)	LENGTH (L)	LENGTH (L1)	DIAMETER (A)	LOCK SCREW	"T" HANDLE ALLEN WRENCH
IEX4-F200T2-60	F200 INTERLOC	M400 INTERLOC	6.000	4.650	2.700	TS-375	3/16
IEX4-F200T2-80			8.000	6.650			
IEX4-F200T2-100			10.000	8.650			
IEX4-F200T2-130			13.000	11.650			

# INTERLOC STRAIGHT REACH EXTENSION

\* Assembles with Master Flange \*

\* Assembles with extensions, reducers, endmill holders and cutterheads \*

**"INTERLOC RIGID"**



INTERLOC EXTENSION  
"M" - MALE CONNECTION

STRAIGHT STYLE

**IEX4-F200S-60**

INTERLOC "F" - FEMALE CONNECTION

LENGTH "L"

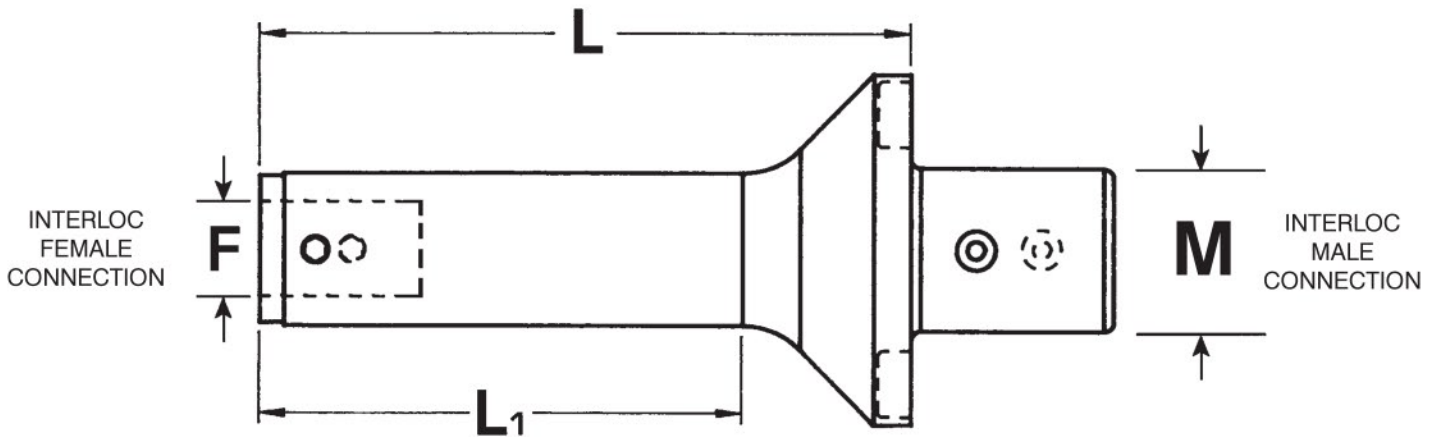
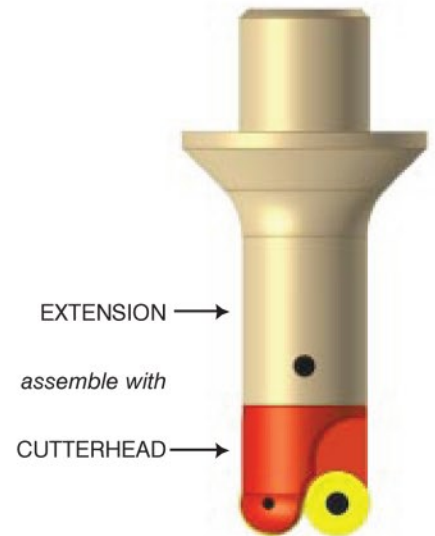

❖ Cooling through shanks available

▲ Custom lengths available

CATALOG NUMBER	INTERLOC FEMALE CONNECTION (F)	INTERLOC MALE CONNECTION (M)	LENGTH (L)	LENGTH (L1)	LOCK SCREW	"T" HANDLE ALLEN WRENCH
IEX4-F200S-25	F200 INTERLOC	M400 INTERLOC	2.500	0.700	TS-375	3/16
IEX4-F200S-60			6.000	4.200		
IEX4-F200S-80			8.000	6.200		
IEX4-F200S-100			10.000	8.200		
IEX4-F200S-130			13.000	11.200		

# INTERLOC FACE MILL EXTENSION

\* Assembles with Master Flange \*

"INTERLOC RIGID"

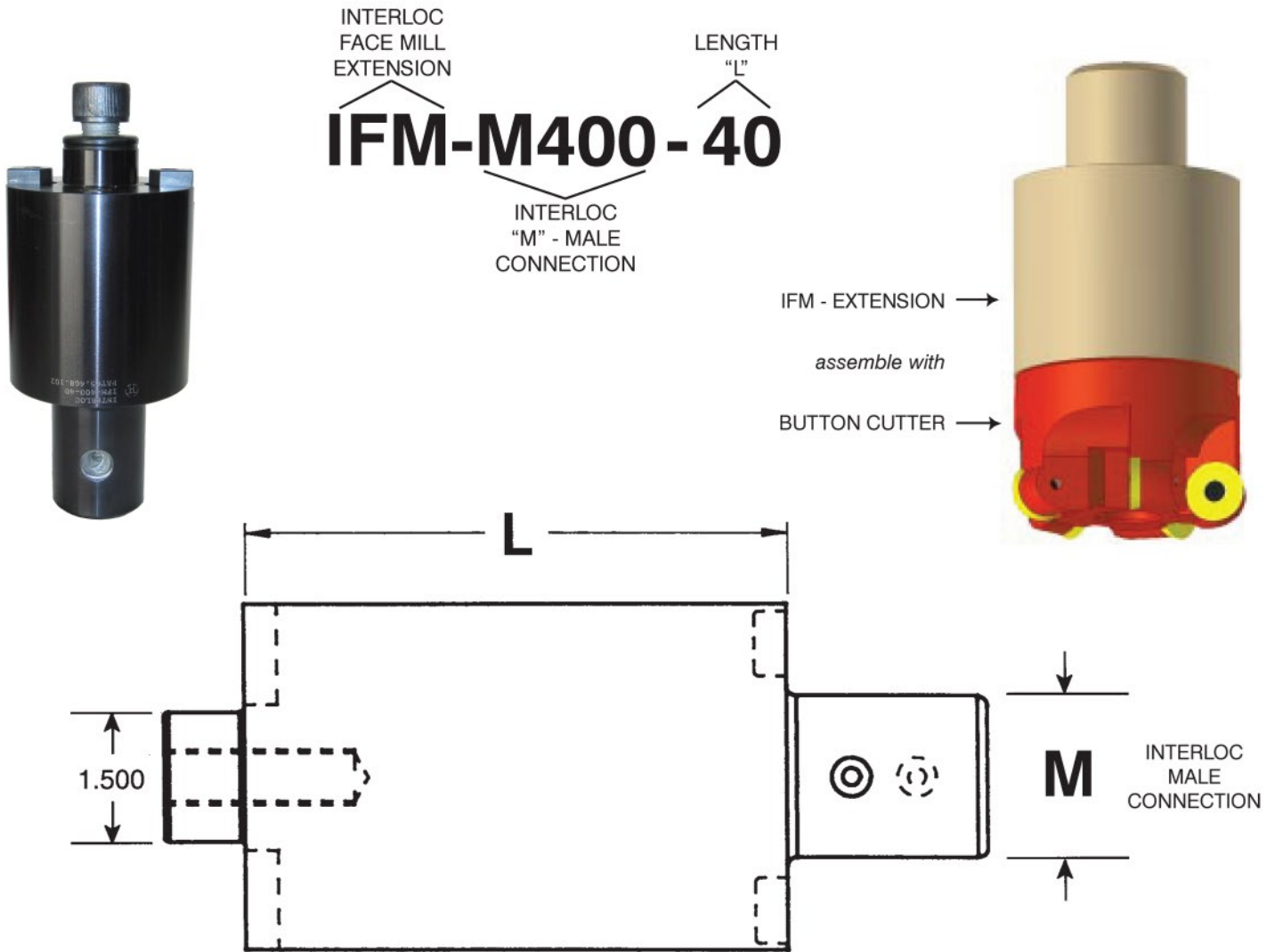

❖ Cooling through shanks available

▲ Custom lengths available

CATALOG NUMBER	INTERLOC FEMALE CONNECTION (F)	LENGTH (L)	KEYWAY	KEYWAY SCREW	CUTTER LOCK SCREW
IFM-M400-15	M400 INTERLOC	1.500	TK-6	10 x 5/8	3/4 - 16 x 1.75
IFM-M400-25		2.500			
IFM-M400-40		4.000			
IFM-M400-80		8.000			
IFM-M400-120		12.000			
IFM-M400-130		13.000			
IFM-M400-140		14.000			

# UNIVERSAL SHANK - INTERLOC SHANK ADAPTERS

- \* Assemble with Master Flange \*
- \* Assembles with IXS shanks \*

**"INTERLOC RIGID"**

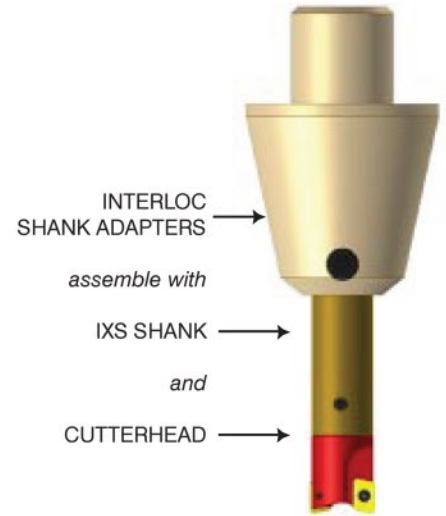
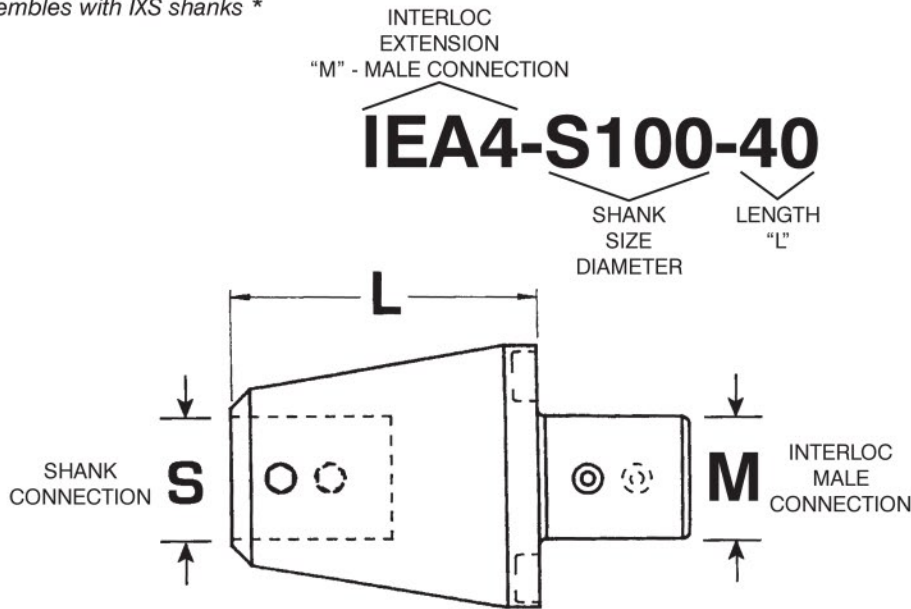

- ❖ Cooling through shanks available
- ▲ Custom lengths available

## INTERLOC EXTENSION - INTERLOC SHANK ADAPTER

CATALOG NUMBER	INTERLOC MALE CONNECTION (M)	SHANK SIZE (S)	LENGTH (L)	LOCK SCREW NUMBER
IEA4-S100-40	M400 INTERLOC	1.000	4.000	TS-500
IEA4-S125-40		1.250		
IEA4-S200-40		2.000		TS-625S



Interloc Shank Adapter

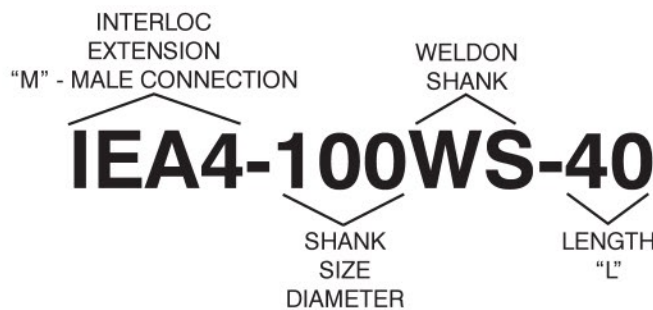

Weldon Flats Shank Adapter

## INTERLOC EXTENSION - WELDON FLATS SHANK ADAPTER

CATALOG NUMBER	INTERLOC MALE CONNECTION (M)	SHANK SIZE (S)	LENGTH (L)	ENDMILL SCREW NUMBER
IEA4-100WS-40*	M400 INTERLOC	1.000	4.000	TS-100E
IEA4-125WS-40*		1.250		
IEA4-200WS-40*		2.000		TS-200E

\*Semi-special