

# INTERLOC TAPERED REACH EXTENSION

\* Assemble with Master Flanges \*  
 \* Assembles with extensions, reducers, endmill holders and cutterheads \*

**"INTERLOC RIGID"**



INTERLOC EXTENSION  
 "M" - MALE CONNECTION

TAPER STYLE

## IEX4-F200T-60

INTERLOC "F" - FEMALE CONNECTION

LENGTH "L"

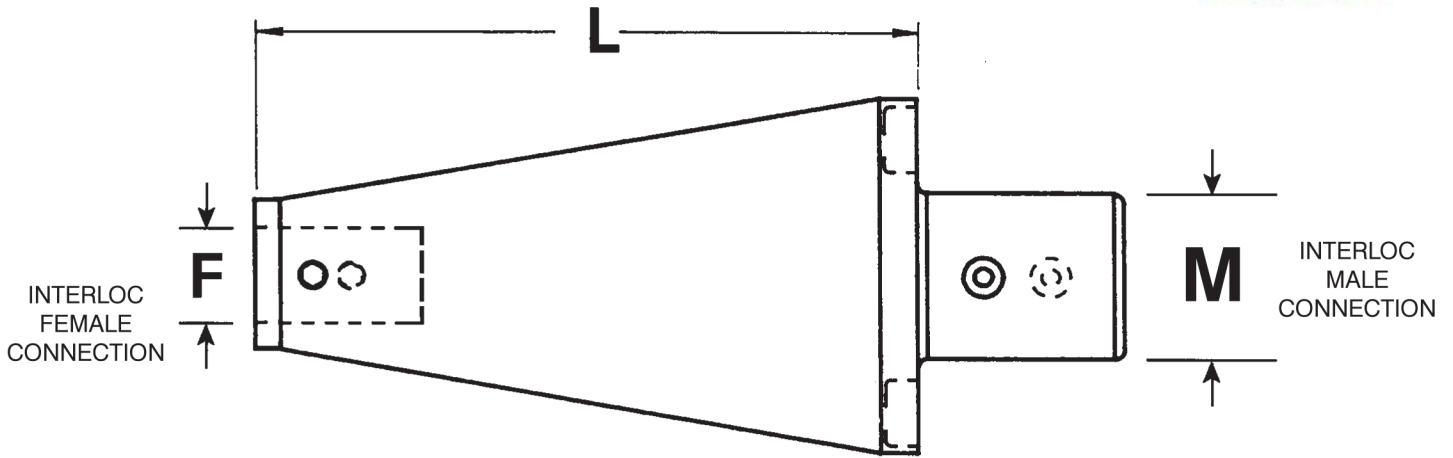
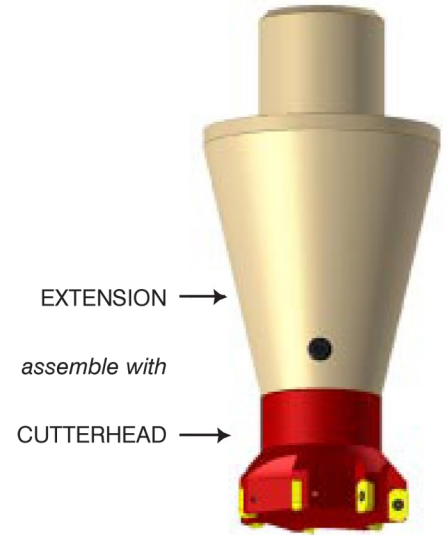

❖ Cooling through shanks available

\* Semi-special

▲ Custom lengths available

CATALOG NUMBER	INTERLOC FEMALE CONNECTION (F)	INTERLOC MALE CONNECTION (M)	LENGTH (L)	LOCK SCREW	"T" HANDLE ALLEN WRENCH
IEX4-F200T-60	F200 INTERLOC	M400 INTERLOC	6.000	TS-375	3/16
IEX4-F200T-80			8.000		
IEX4-F200T-100			10.000		
IEX4-F200T-130			13.000		
IEX4-F200T-180*			18.000		

# INTERLOC TAPERED II REACH EXTENSION

\* Assembles with Master Flange \*  
 \* Assembles with extensions, reducers, endmill holders and cutterheads \*

**"INTERLOC RIGID"**



INTERLOC EXTENSION  
 "M" - MALE CONNECTION

TAPER STYLE #2

## IEX4-F200T2-60

INTERLOC "F" - FEMALE CONNECTION

LENGTH "L"

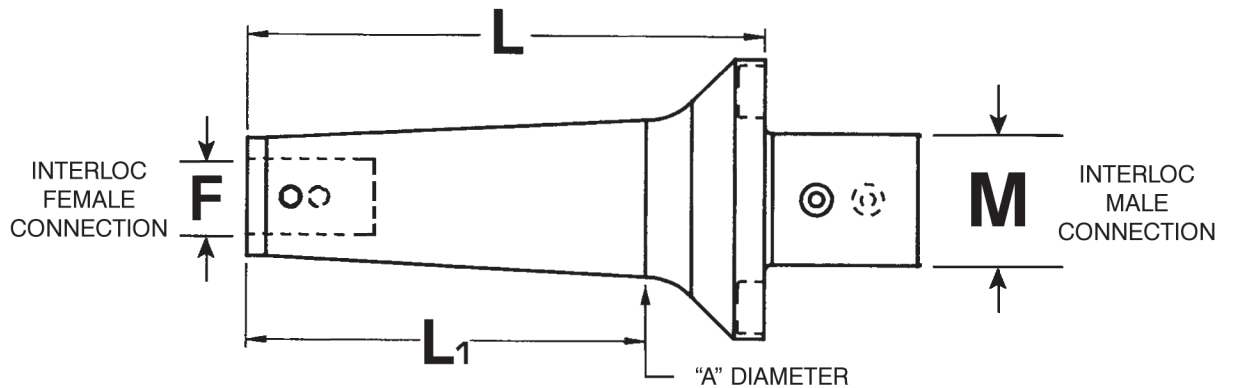
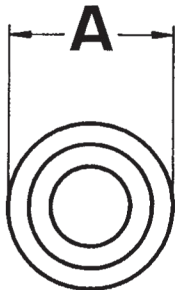
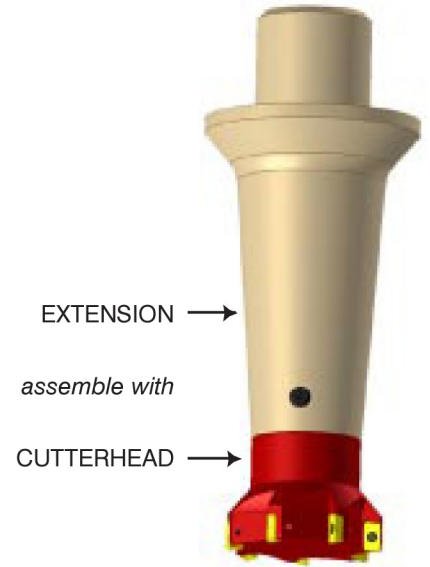

❖ Cooling through shanks available

▲ Custom lengths available

CATALOG NUMBER	INTERLOC FEMALE CONNECTION (F)	INTERLOC MALE CONNECTION (M)	LENGTH (L)	LENGTH (L <sub>1</sub> )	DIAMETER (A)	LOCK SCREW	"T" HANDLE ALLEN WRENCH
IEX4-F200T2-60	F200 INTERLOC	M400 INTERLOC	6.000	4.650	2.700	TS-375	3/16
IEX4-F200T2-80			8.000	6.650			
IEX4-F200T2-100			10.000	8.650			
IEX4-F200T2-130			13.000	11.650			

# INTERLOC STRAIGHT REACH EXTENSION

\* Assembles with Master Flange \*

\* Assembles with extensions, reducers, endmill holders and cutterheads \*

**"INTERLOC RIGID"**



INTERLOC EXTENSION  
"M" - MALE CONNECTION

STRAIGHT STYLE

**IEX4-F200S-60**

INTERLOC "F" - FEMALE CONNECTION

LENGTH "L"

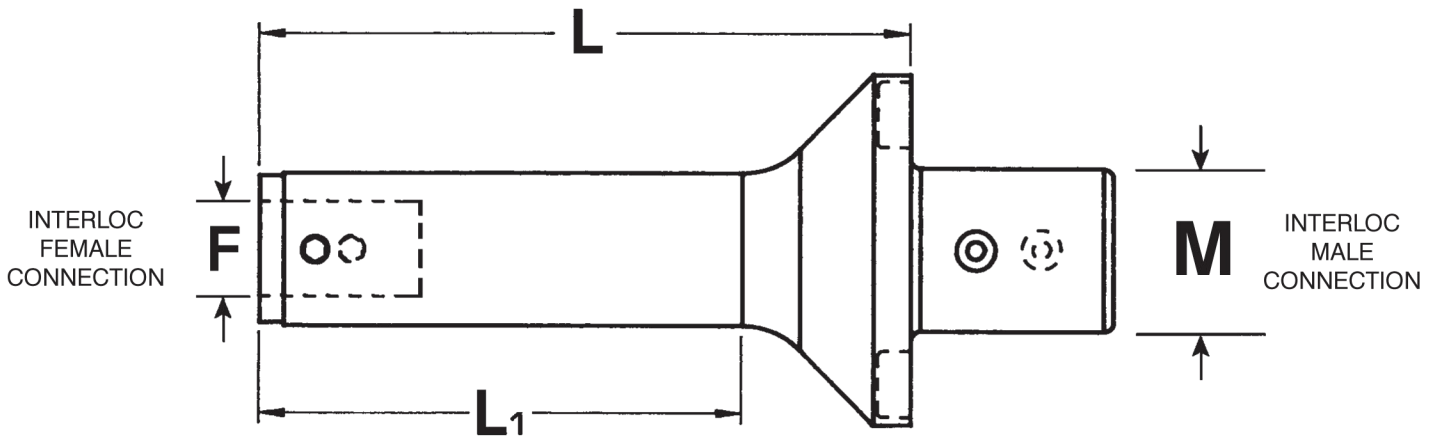
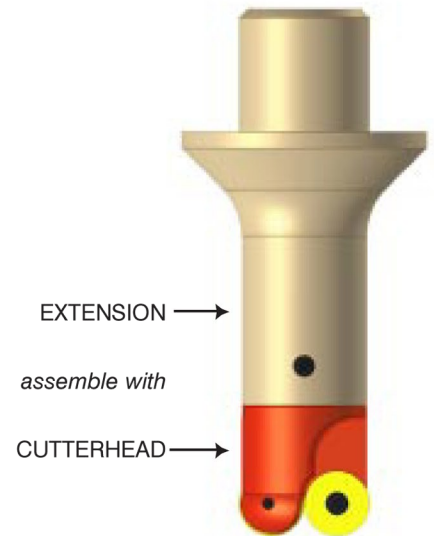

❖ *Cooling through shanks available*

▲ *Custom lengths available*

CATALOG NUMBER	INTERLOC FEMALE CONNECTION (F)	INTERLOC MALE CONNECTION (M)	LENGTH (L)	LENGTH (L1)	LOCK SCREW	"T" HANDLE ALLEN WRENCH
IEX4-F200S-25	F200 INTERLOC	M400 INTERLOC	2.500	0.700	TS-375	3/16
IEX4-F200S-60			6.000	4.200		
IEX4-F200S-80			8.000	6.200		
IEX4-F200S-100			10.000	8.200		
IEX4-F200S-130			13.000	11.200		