

ULTRA DRIVE CDEW CUTTERHEADS

* Assembles with shanks *

"ULTRA DRIVE SYSTEM"

GRADE SELECTION

IAN 5	ALLOY STEEL
HN	HIGH NICKEL BASE MATERIAL STAINLESS STEEL
TA	TITANIUM
T18	ALUMINUM

INSERT STYLE LENGTH "L" ULTRA DRIVE STYLE
 ┌───────────┬───────────┬───────────┐
32-CDE4-20-100
 └───────────┘ └───────────┘
 CUTTING DIAMETER NUMBER OF FLUTES

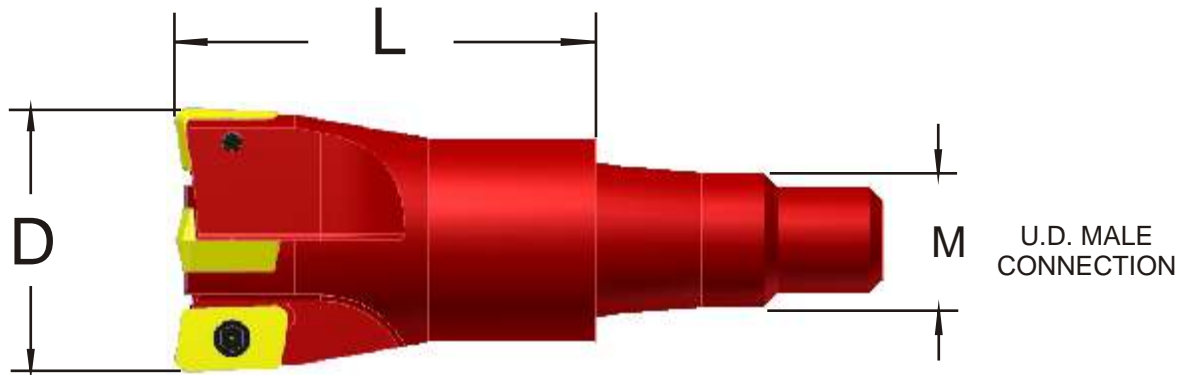

- ** Not In-Stock Item
- ❖ Cooling through shanks available
- Cutting diameter and insert clearance is based on .0625 R insert.
- Custom sizes available

CATALOG NUMBER	ULTRA DRIVE MALE CONNECTION (M)	EFFECTIVE CUTTING DIAMETER (D)	LENGTH (L)	NUMBER OF FLUTES	INSERT NUMBER	INSERT SCREW NUMBER	TORX WRENCH
20CDE2-20-750	M75	20	2.000	2	CDEW-322 TO CDEW-328	TS3CD	T9
25CDE2-20-750		25					
20CDE2-30T-100	M10	20	3.000	4			
25CDE2-20-100		25	2.000				
32CDE4-20-100		32					
25CDE2-20-125 **		25					
32CDE4-20-125		32					