

ULTRA DRIVE BD-CDEW CUTTERHEADS

* Assembles with shanks *

"ULTRA DRIVE SYSTEM"

GRADE SELECTION

IAN 5	ALLOY STEEL
HN	HIGH NICKEL BASE MATERIAL STAINLESS STEEL
TA	TITANIUM
TI8	ALUMINUM

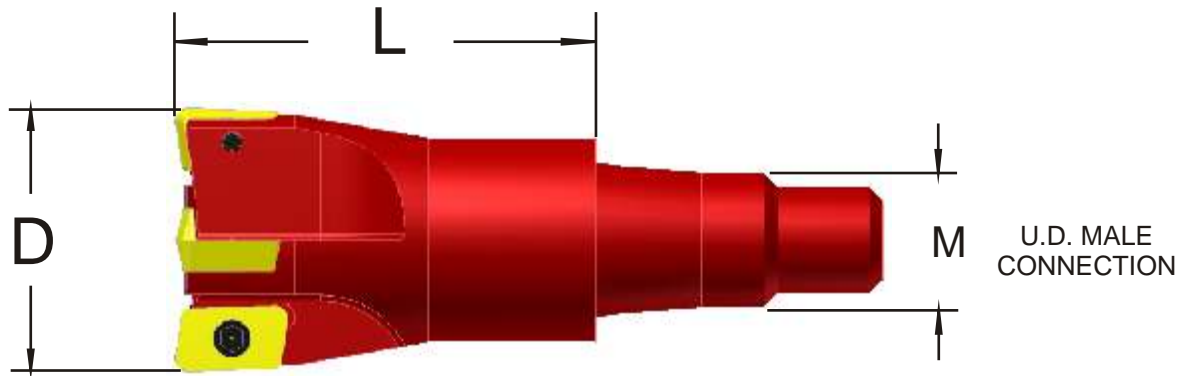
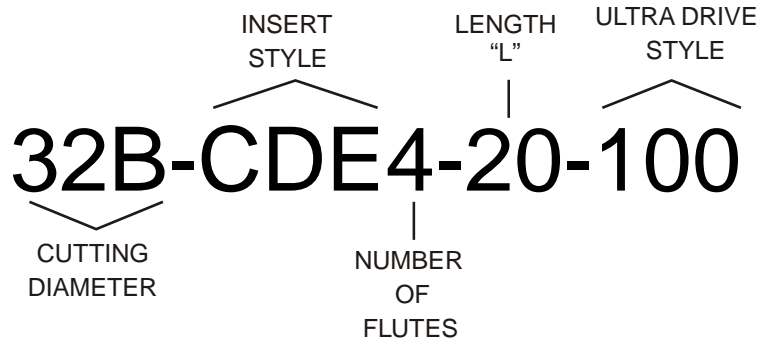

- ** Not In-Stock Item
- ❖ Cooling through shanks available
- Cutting diameter and insert clearance is based on .0625 R insert.
- Custom sizes available

CATALOG NUMBER	ULTRA DRIVE MALE CONNECTION (M)	EFFECTIVE CUTTING DIAMETER (D)	LENGTH (L)	NUMBER OF FLUTES	INSERT NUMBER	INSERT SCREW NUMBER	TORX WRENCH
20B-CDE2-20-750	M75	20	2.000	2	CDEW-324	TS3CD	T9
25B-CDE2-20-750		25					
20B-CDE2-30T-100	M10	20	3.000	4			
25B-CDE2-20-100		25	2.000				
32B-CDE4-20-100		32		4			
25B-CDE2-20-125 **		25					
32B-CDE4-20-125		32					