

# ULTRA DRIVE CDEW CUTTERHEADS

\* Assembles with shanks \*

"ULTRA DRIVE SYSTEM"

## GRADE SELECTION

<b>IAN 5</b>	ALLOY STEEL
<b>HN</b>	HIGH NICKEL BASE MATERIAL STAINLESS STEEL
<b>TA</b>	TITANIUM
<b>TI8</b>	ALUMINUM

INSERT STYLE      LENGTH "L"      ULTRA DRIVE STYLE  
**125-CDE4-20-100**  
 CUTTING DIAMETER      NUMBER OF FLUTES

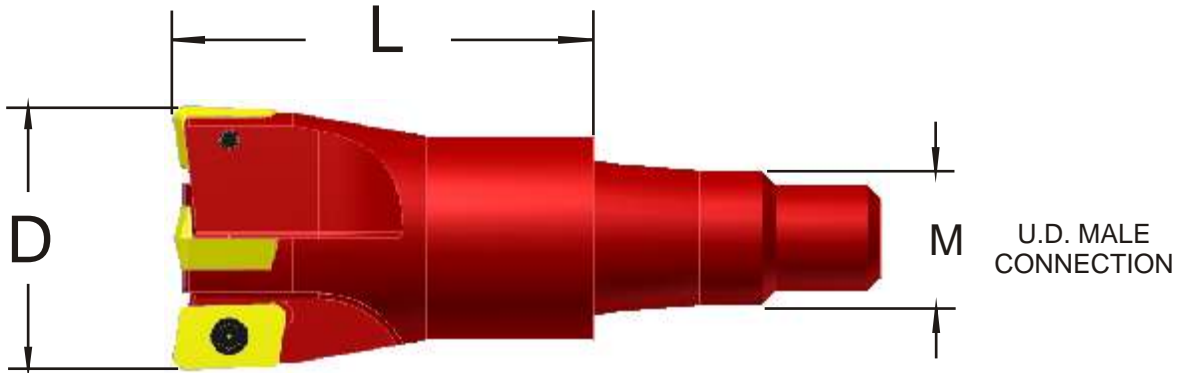

- \*\* Not In-Stock Item
- ❖ Cooling through shanks available
- Cutting diameter and insert clearance is based on .0625 R insert.
- Custom sizes available

CATALOG NUMBER	ULTRA DRIVE MALE CONNECTION (M)	EFFECTIVE CUTTING DIAMETER (D)	LENGTH (L)	NUMBER OF FLUTES	INSERT NUMBER	INSERT SCREW NUMBER	TORX WRENCH
75CDE2-20-750	M75	0.750	2.000	2	CDEW-322 TO CDEW-328	TS3CD	T9
100CDE2-20-750		1.000					
75CDE2-30T-100	0.750	3.000					
100CDE2-20-100	M10	1.000	2.000	3			
100CDE3-20-100		1.250		4			
125CDE4-20-100		1.250		4			
150CDE4-20-125		1.500		4			
200CDE5-20-200	M20	2.000	2.000	5			
275CDE6-20-200		2.700		6			
275CDE7-20-200 **		2.700		7			