

ULTRA DRIVE BD-CDEW CUTTERHEADS

* Assembles with shanks *

"ULTRA DRIVE SYSTEM"

GRADE SELECTION

IAN 5	ALLOY STEEL
HN	HIGH NICKEL BASE MATERIAL STAINLESS STEEL
TA	TITANIUM
TI8	ALUMINUM

INSERT STYLE LENGTH "L" ULTRA DRIVE STYLE
150B-CDE4-20-125
 CUTTING DIAMETER NUMBER OF FLUTES

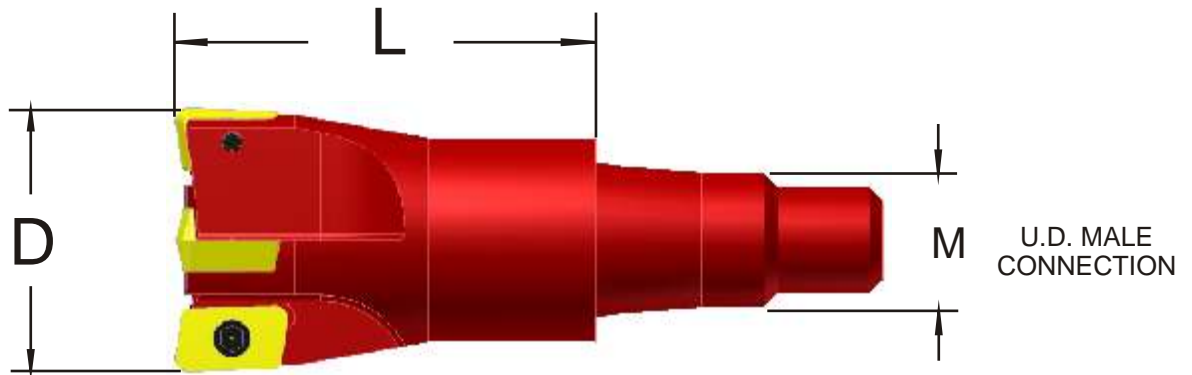

- ** Not In-Stock Item
- ❖ Cooling through shanks available
- Cutting diameter and insert clearance is based on .0625 R insert.
- Custom sizes available

CATALOG NUMBER	ULTRA DRIVE MALE CONNECTION (M)	EFFECTIVE CUTTING DIAMETER (D)	LENGTH (L)	NUMBER OF FLUTES	INSERT NUMBER	INSERT SCREW NUMBER	TORX WRENCH	
50B-CDE1-30T-750	M75	0.500	3.000	1	CDEW-324	TS3CDS	T9	
75B-CDE2-20-750		0.750	2.000	2		TS3CD		
100B-CDE2-20-750		1.000						
75B-CDE2-30T-100	M10	0.750	3.000					3
100B-CDE2-20-100		1.000	2.000	4				
100B-CDE3-20-100		1.250						
125B-CDE4-20-100		1.250						4
125B-CDE4-20-125		1.500						
150B-CDE4-20-125		2.000						
200B-CDE5-20-200	M20	2.000	2.000	5				
275B-CDE6-20-200		2.750		6				
275B-CDE7-20-200 **		2.750		7				