

ULTRA DRIVE - BALL NOSE CUTTERHEADS

* Assembles with shanks *

"ULTRA DRIVE SYSTEM"

CUTTING DIAMETER
 LENGTH "L"
50A-30T-100
 INSERT STYLE TAPER STYLE ULTRA DRIVE STYLE

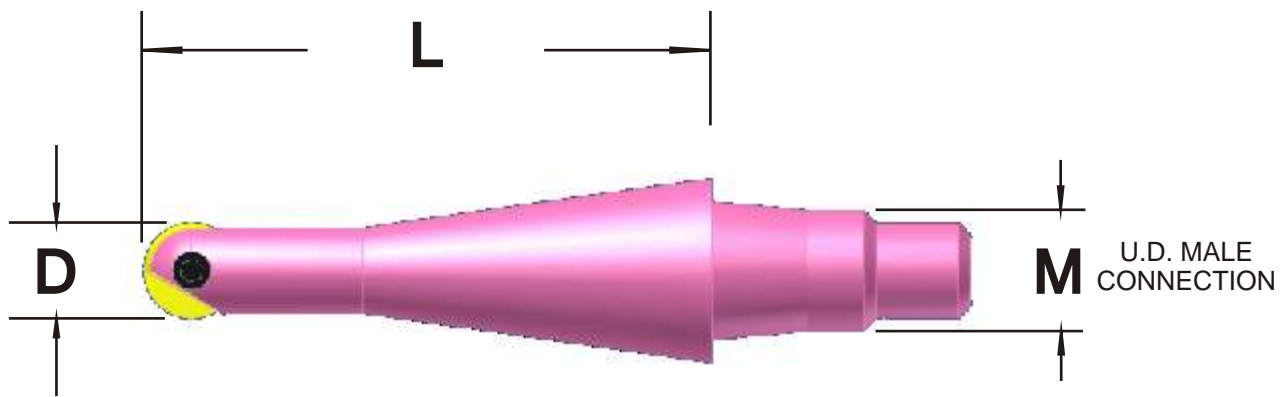

- ** Not In-Stock Item
- ❖ Cooling through shanks available
- Custom sizes available

INCH				METRIC				
CATALOG NUMBER	ULTRA DRIVE MALE CONNECTION (M)	EFFECTIVE CUTTING DIAMETER (D)	LENGTH (L)	NUMBER OF FLUTES	INSERT NUMBER	INSERT SCREW NUMBER	TORX WRENCH	METRIC TOOLS ARE SAME AS INCH ONLY THE INSERT IS METRIC (XXX)
38A-30T-750	M75	.375 / 10	3.000	2	ARF-380 / ARF-10	TS-38A	T-8	(XXX)
50A-30T-750		.500 / 12			ARF-500 / ARF-12	TS-50A	T-10	(XXX)
75A-20-750		.750 / 16			ARF-750 / ARF-16	TS-75A	T-20	(XXX)
38A-30T-100 **	M10	.375 / 10	3.000		ARF-380 / ARF-10	TS-38A	T-8	(XXX) **
50A-30T-100 **		.500 / 12			ARF-500 / ARF-12	TS-50A	T-10	(XXX) **
75A-30T-100		.750 / 16			ARF-750 / ARF-16	TS-75A	T-20	(XXX)
100A-20-100		1.000 / 25			ARF-100 / ARF-25	TS-100A	T-30	(XXX)
75A-30T-125		.750 / 16			ARF-750 / ARF-16	TS-75A	T-20	(XXX)
100A-30T-125		1.000 / 25			ARF-100 / ARF-25	TS-100A	T-30	(XXX)
125A-20-125	1.250 / 32	ARF-125 / ARF-32	TS-125A		T-40	(XXX)		
75A-30T-200 **	M20	.750 / 16	3.000		ARF-750 / ARF-16	TS-75A	T-20	(XXX) **
100A-30T-200 **		1.000 / 25			ARF-100 / ARF-25	TS-100A	T-30	(XXX) **
125A-30T-200 **		1.250 / 32		ARF-125 / ARF-32	TS-125A	T-40	(XXX) **	