

ULTRA DRIVE CAT 50V SHANKS

* Assembles with endmill holders and cutterheads *

"ULTRA DRIVE SYSTEM"

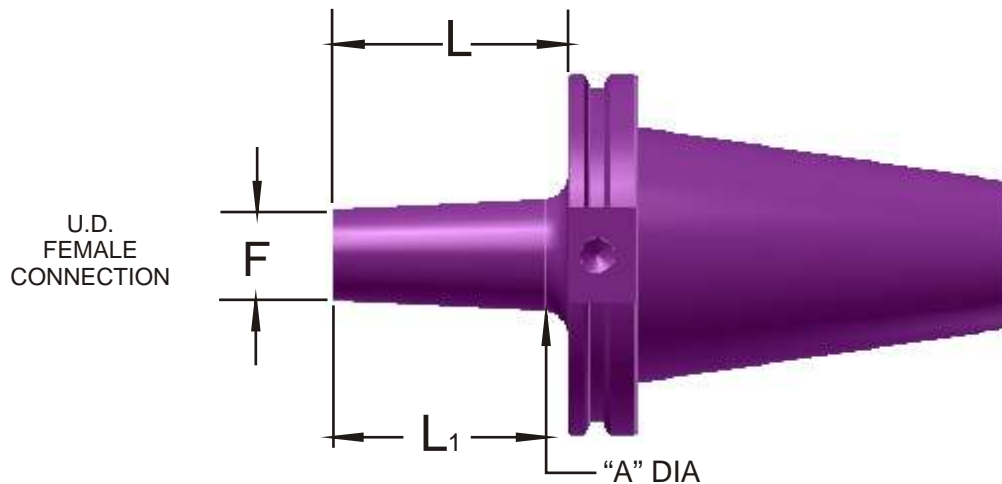
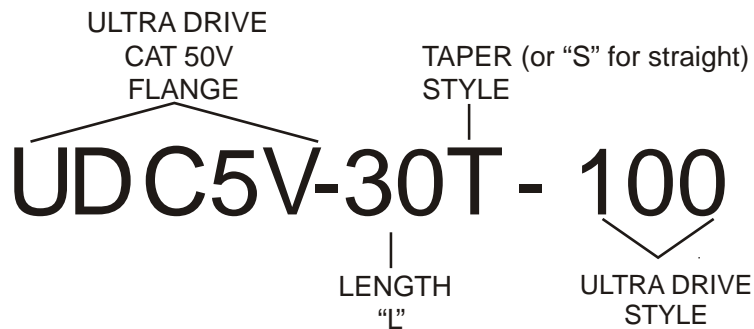

▲ Custom lengths available

CATALOG NUMBER	ULTRA DRIVE FEMALE CONNECTION	DIAMETER (A)	LENGTH (L)	LENGTH (L1)	LOCK SCREW NUMBER	"T" HANDLE ALLEN WRENCH
UDC5V-30T-750	F75	.990	3.000	2.770	TS-7M	5M
UDC5V-40T-750			4.000	3.770		
UDC5V-30T-100	F10	1.240	3.000	2.770	TS-8M	6M
UDC5V-40T-100			4.000	3.770		
UDC5V-30T-125		1.490	3.000	2.830		
UDC5V-40T-125			4.000	3.830		
UDC5V-30S-200	F20	1.950	3.000	2.890	TS-8M	6M
UDC5V-40S-200			4.000	3.890		
UDC5V-30T-200		2.240	3.000	2.770		
UDC5V-40T-200			4.000	3.770		